

FLEXSIL®

Refractory Cloth Filters

Low cost, high efficiency
filtration for metals

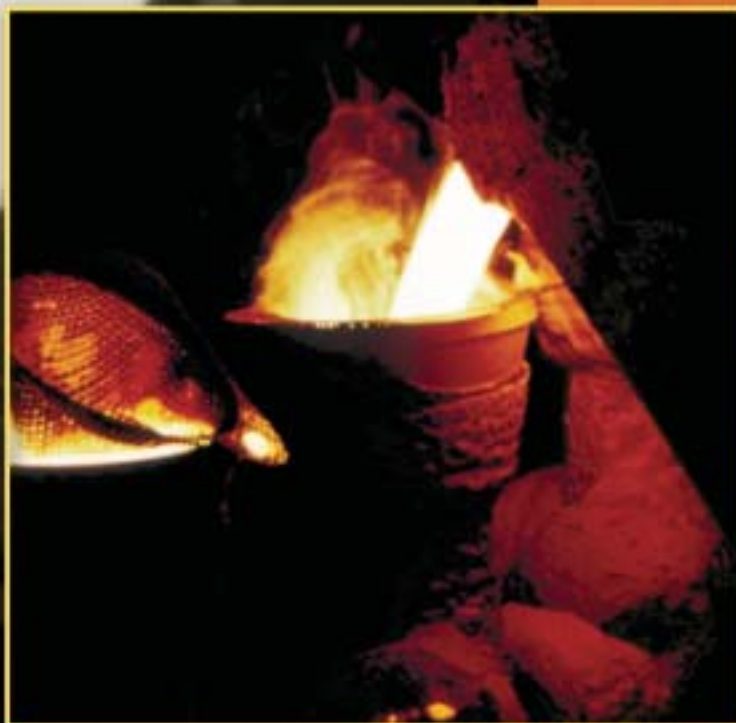

AMETEK®
CHEMICAL PRODUCTS
HAVEG

AMETEK®
FLEXSIL®

Refractory Cloth Filters

FLEXSIL® refractory cloth filters are designed to extract dross, slag, refractory particles, and non-metallic inclusions from molten metals. FLEXSIL filters were developed as a low cost, high efficiency alternative to cellular ceramic and reticulated ceramic foam filtration systems. Made from specially treated silica fibers, FLEXSIL filters are capable of withstanding pouring temperatures ranging up to 3000°F (1620°C).

FLEXSIL filters are ideal for in-mold filtration of gray, malleable, white, compacted graphite, and ductile cast irons, as well as non-ferrous aluminum and copper-based metal alloys. FLEXSIL filters are available in a choice of mesh sizes, and can be cut or formed to virtually any desired size or shape. FLEXSIL cloth is also available in 25- or 50-yard rolls.

Chemically active filter surface

FLEXSIL silica cloth filters trap impurities using a method uniquely different than that of mullite

or alumina filters. When molten ferrous metal contacts a FLEXSIL filter, special surface coatings decompose to instantly form a continuous film of fayalite ($2\text{FeO}\cdot\text{SiO}_2$). The fayalite coating becomes soft and viscous at high temperatures to entrap inclusions that come into contact with it. The resulting sticky film enables even micron-size inclusions to be filtered out of the very first metal to pass through the filter.

In magnesium treated ductile iron filtration, the fayalite coating absorbs magnesium reaction products contained in the molten metal. Low melting solid solutions are formed on the surface of the silica fibers to help remove inclusions, especially magnesium dross, sulfides, and silicates formed by the nodularizing treatment. Conventional hard-fired ceramic filters composed of alumina or mullite cannot capture inclusions in this way because alumina and mullite do not form a fayalite coating. FLEXSIL filters are especially effective in removing fluid slags, such as manganese silicates, from cast iron.



Filtration Applications

Typical FLEXSIL Placements

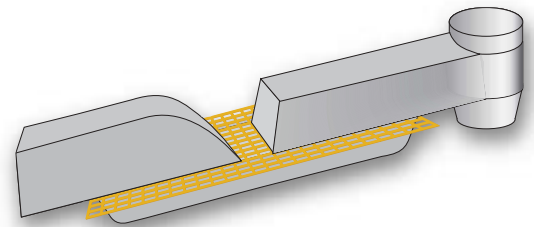
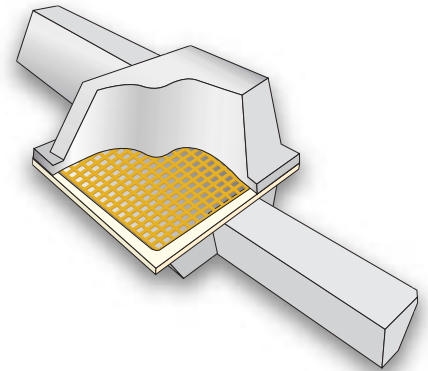
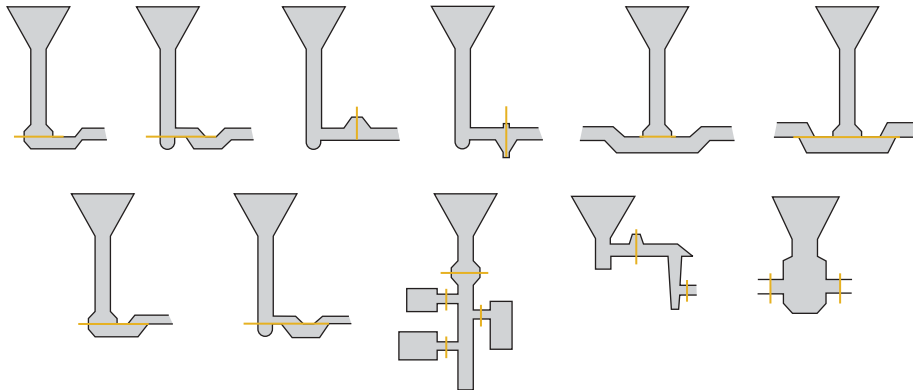

Multiple Crossover Filtration

FLEXSIL filters can be positioned across down-sprues, and horizontally or vertically across runners for single or multiple filtration. A single strip of FLEXSIL can provide multiple filtration by a “down” then “up” flow pattern. This arrangement produces the cleanest metal at the lowest cost.

Other Applications

De-Risering and Runner Segmentation

Cut sections and core sand-reinforced filter cloth can be placed across casting and riser in-gates for filtration and shake out de-risering. Small sections of FLEXSIL may also be placed directly into ports in cores to achieve filtration and knock-off. De-risering of ductile iron castings may be easily accomplished using FLEXSIL containing cores on casting with top risers. Savings of 50% or more can be realized through riser removal.

Investment Casting

Small rigid FLEXSIL filter cups require no pre-heating and can be placed directly into hot refractory pouring cups just seconds before the pour, to provide efficient, low cost filtration. The spent filter and accompanying impurities can be easily removed prior to solidification. This results in cleaner remelt material. Small cut pieces of FLEXSIL can be easily placed directly into wax or Styrofoam runners. After burnout, the edges of the filter are held rigidly in-place by the ceramic shell.

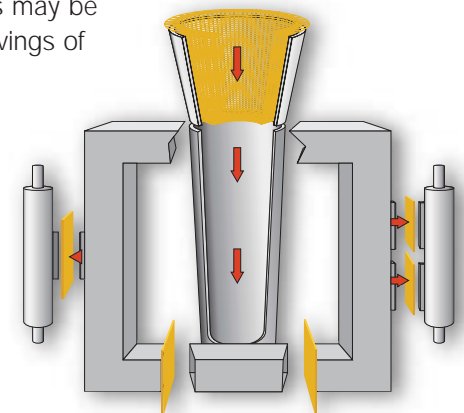

FLEXSIL®

AMETEK cannot predict all of the potential applications for which customers may attempt to use FLEXSIL® products. FLEXSIL products may have varying degrees of effectiveness for each potential application, depending on numerous variables of the casting process. AMETEK makes no express or implied warranties, including warranties of merchantability or fitness for any particular purpose for FLEXSIL products. This product is not warranted against injuries or damages of any kind, including, but not limited to scrap cores, molds, or castings. If you have questions about the use of FLEXSIL products, please contact us at (302) 995-0400.

AMETEK is a leading global manufacturer of electronic instruments and electric motors for niche markets. Listed on the New York Stock Exchange (AME) since 1930, AMETEK's annual sales are more than \$1 billion at plants and operations in the United States and 15 other countries.

AMETEK®

**CHEMICAL PRODUCTS
HAVEG**

900 Greenbank Road, Wilmington DE 19808
Tel: 302-995-0400 800-441-7777
Fax: 302-995-0491
E-mail: info.haveg@ametek.com
www.ametekhaveg.com



© 2003, by AMETEK, Inc. All rights reserved.
.5M703A (040065)

